

Model: GP-CVP024N-xxV-P02 Series

■ Features

- Universal AC Input Range 90 ~ 264VAC.
- Constant Voltage mode.
- Protections: OCP / SCP.
- Surge protection with 2KV.
- High Efficiency up to 88 %.
- Fully Insulated Plastic Case.
- No-load power consumption < 0.5W at 230VAC.
- Set up time < 0.5S at 230VAC.
- Suitable for LED strips, light box, channel letters, neon lights and cabinet lights applications.
- Compact size suitable for installation in light box.

■ Approvals

CE LPS IP66



■ Size

85 x 35 x 22mm (L x W x H)



■ Specifications

Model No.	GP-CVP024N-12V-P02	GP- CVP024N -24V-P02	GP- CVP024N -48V-P02	
Output	DC Voltage	12V	24V	48V
	Rated Current	0~2A	0~1A	0~0.5A
	Rated Power	24W	24W	24W
	Ripple & Noise (Max.) Note.2	240mV	280mV	320mV
	Efficiency at 230VAC (Typ.)	88%	88%	88%
	Voltage Tolerance Note.3	± 5%	± 5%	± 5%
	Set up time (Max.)	≤ 0.5S at 230VAC, full load.		
Input	Rated Voltage	100 ~ 240VAC 141~340VDC		
	Voltage Range	90 ~ 264VAC		
	Frequency Range	47 Hz ~ 63 Hz		
	AC Current (Max.)	0.48A at 115VAC / 0.30A at 230VAC		
	Inrush Current (Typ.)	Cold Start 50A (Td=250us measured at 50% Ipeak) at 230VAC		
	Max. Number of PSUs on Circuit Breaker	B type : 6 units (10A) / 10 units (16A) / 16 units (25A), C type : 11 units (10A) / 17 units (16A) / 27 units (25A), D type : 26 units (16A) / 41 units (25A) at 230VAC		
	Leakage Current	<1mA@230VAC		
	No-load power consumption	< 0.5W at 230VAC (0.2W Typ.)		
Protections	Over Current	2.2A~3A	1.1A~1.5A	0.55A~0.75A
	Short Circuit	Type: Hiccup mode (Auto recover after fault condition disappeared).		

Environment	Operation Temp.	-30°C ~50°C (Refer to output load de-rating curve).
	Operation Humidity	20% ~ 90% RH non-condensing.
	Storage Temp.	-30 ~ +50°C
	Storage Humidity	10% ~ 90% RH
	Vibration	10~500 Hz, 2G 10 min./1 cycle, period for 60 min. each along X, Y, Z axes.
Safety& EMC	Safety Standards	EN62368-1
	Withstand Voltage	I/P-O/P: 3.75KVAC
	Isolation Resistance	I/P-O/P :100M ohms / 500V DC at 25°C
	EMI Conduction & Radiation	Compliance to EN55032
	Harmonic Current	Compliance to EN61000-3-2, EN61000-3-3
	EMS Immunity	Compliance to EN61000-4-2,3,4,5,6,11
Others	MTBF	50K hours min. MIL-HDBK-217F(50°C)
	Dimension(L x W x H)	85 x 35 x 22mm; 115 g/pcs
Note	<p>1. All specifications not specially mentioned are measured at 230VAC full load and 25°C ambient temperature.</p> <p>2. Ripple & Noise are measured at 20MHz bandwidth by using a 12" twisted pair-wire terminated with 0.1uf & 47uf parallel capacitor.</p> <p>3. Voltage Tolerance: includes line regulation, load regulation and set-up tolerance.</p> <p>4. The power supply is considered a component which will be installed a final equipment. The final equipment must be re-confirmed that it still meets EMC directives.</p>	

■ **Derating Curve**

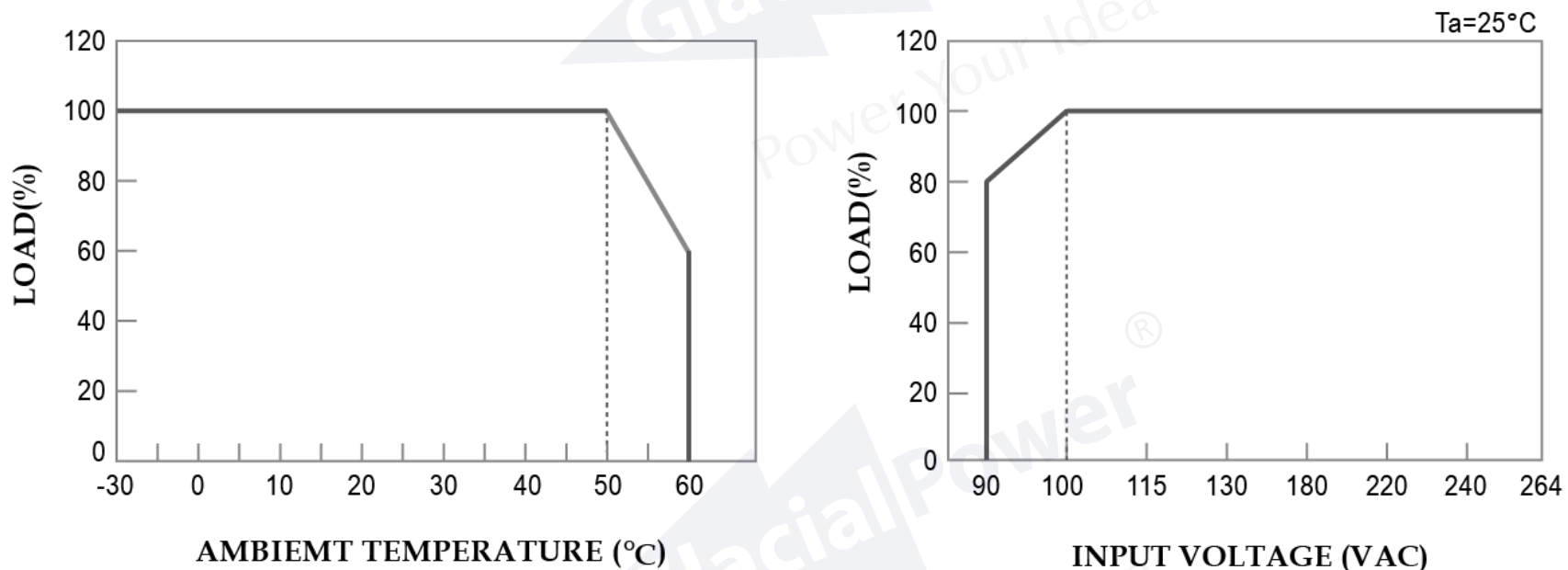

■ **Mechanical Specification**

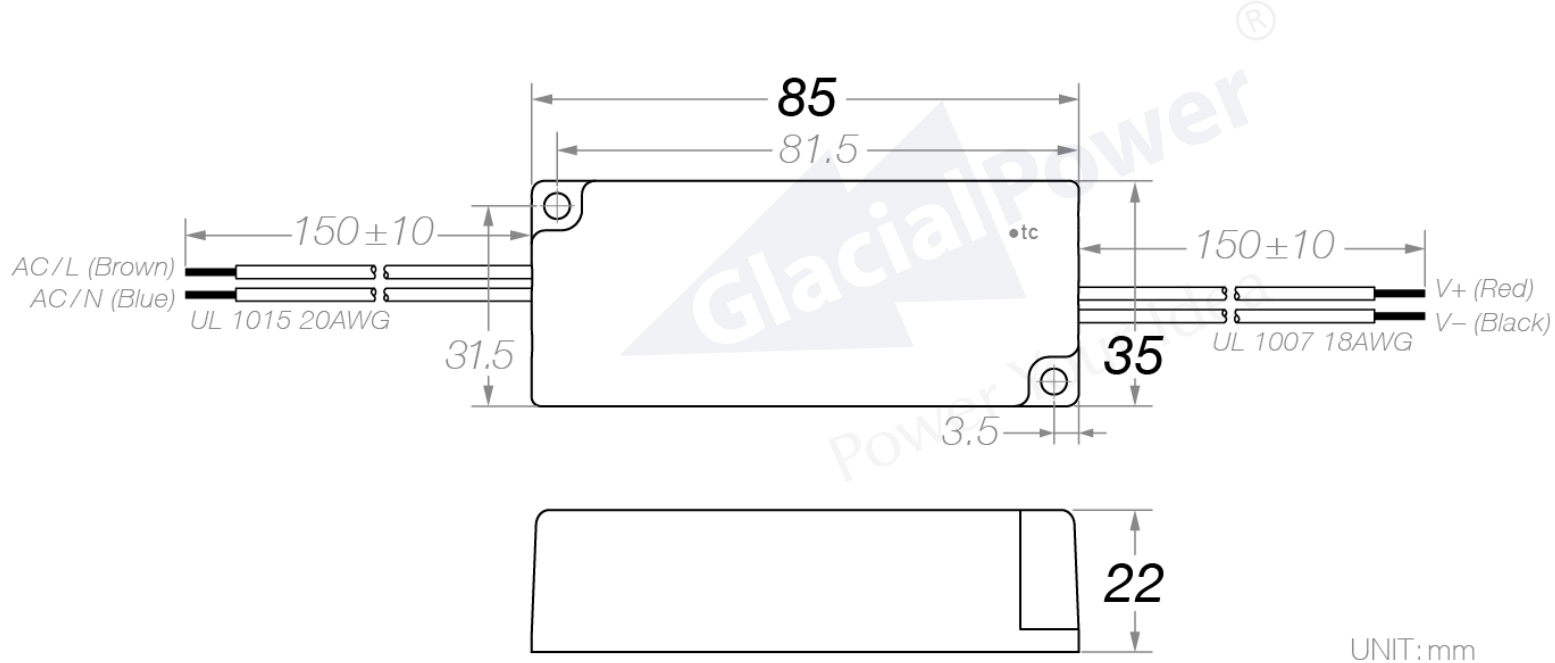

GP-CVP024N-12V-P02



GP-CVP024N-24V-P02



GP-CVP024N-48V-P02

■ **Application** (Compact size suitable for installation in light box)

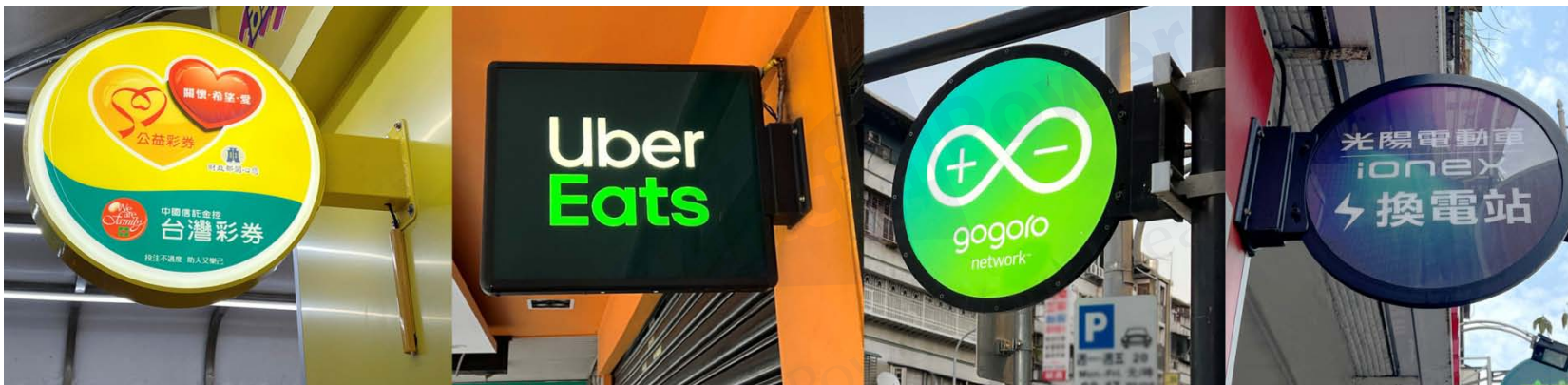

■ **Application** (Compact size suitable for installation in light box)



GlacialPower®
Power Your Idea

GlacialPower®
Power Your Idea