

Model: GP-CVM400P Series

■ Features

- Universal AC input range 90 ~ 305VAC.
- Constant voltage mode.
- Active PFC design.
- Protections: OVP / OCP / SCP / OTP.
- High efficiency up to 93.5%
- Fully insulated case with IP67 rated.
- Surge protection with 4KV/2KV.
- Cooling by free air convection (Metal Housing)
- No-load power consumption < 0.5W at 230VAC (for non-dimming models).
- Standby power consumption < 0.5W at 230VAC (for dimming models).
- Suitable for LED strips and moving sign applications.
- 3-in-1 dimming (dim-to-off) and DALI-2 functions available.
- The output and dimming lines are compliant with the new regulations with isolation.

■ Approvals



■ Size

300 x 98 x 38.5mm (L x W x H)



■ Specifications

Note: GP-CVM400P-xxV(X): xx=12,24,36,48V (X)=Blank → Non DIM. , (X)=A → 3-in-1 DIM. , (X)=D2 → DALI-2 DIM.

Model No.	GP-CVM400P-12V(X)	GP-CVM400P-24V(X)	GP-CVM400P-36V(X)	GP-CVM400P-48V(X)	
Output	DC Voltage	12V	24V	36V	48V
	Rated Current	0~26.7A	0~16.7A	0~11.1A	0~8.3A
	Rated Power	320.4W	400.8W	399.6W	398.4W
	Ripple & Noise (Max.) Note.2	300mV	350mV	400mV	500mV
	Efficiency at 230VAC (Typ.)	92.5%	93%	93%	93.5%
	Voltage Tolerance Note.3	± 5%	± 5%	± 5%	± 5%
	PWM Dimming (optional)	> 1600 Hz (for dimmable version)			
	Set up time (Max.)	0.5s / 230VAC, 1s / 115VAC, at full load. 0.7s / 230VAC for DALI2 version			

Input	Rated Voltage	100 ~ 277VAC			
	Voltage Range	90 ~ 305VAC			
	Frequency Range	47 Hz ~ 63 Hz			
	AC Current (Max.)	4.5A at 115VAC / 2.3A at 230VAC			
	Power Factor	> 0.98 at 115VAC / >0.94 at 230VAC at full load. PF ≥ 0.9 at 70% load			
	Total Harmonic Distortion	THD < 15% at 230VAC, full load. <small>Note 4</small>			
	Inrush Current (Typ.)	Cold Start 120A (Td=960us measured at 50% Ipeak) at 230VAC			
	Max. Number of PSUs on Circuit Breaker	B type : 1 unit (16A) / 1 unit (25A), C type : 1 unit (10A) / 1 unit (16A) / 2 units (25A), D type : 3 units (16A) / 5 units (25A) at 230VAC			
	Leakage Current	<1mA / 240VAC			
DIM. Control (3-in-1)	DC dimming	DC 0-10V			
	PWM dimming	Puls:Hi=10V Low=0V, Duty:0%~100%, Fsw 0.5-3KHz			
	Resistance dimming	0KΩ~100KΩ or Electronic Potentiometer 0-10V			
DIM. Control (DALI-2)	DALI-2 Standards	IEC 62386-101, 102 and 207			
	DALI bus current consumption	< 2mA			
Protections	Over Current	105~180% rated current. Type: Hiccup mode (Auto recover after fault condition disappeared).			
	Short Circuit	Type: Hiccup mode (Auto recover after fault condition disappeared).			
	Over Voltage	13~19V	26~38V	38V~50V	50V~65V
		Type: Hiccup mode (Auto recover after fault condition disappeared).			
Over Temperature	Tcase: 95°C ± 10°C				
	Type: Latch off mode (re-power on to recover).				
Environment	Operation Temp.	-30°C ~50°C (Refer to output load derating curve).			
	Operation Humidity	20% ~ 90% RH non-condensing.			
	Storage Temp.	-40 ~ +80°C			
	Storage Humidity	10% ~ 90% RH			
	Vibration	10~500 Hz, 2G 10 min./1 cycle, period for 60 min. each along X, Y, Z axes.			
Safety& EMC	Safety Standards	EN61347-1,EN61347-2-13 ,independent,IP67 Approved.			
	Withstand Voltage	I/P-O/P: 3.75KVAC I/P-FG:1.88KVAC O/P-FG:0.5KVAC			
	Isolation Resistance	I/P-O/P,I/P-FG : 100M ohms , O/P-FG : 4M ohms / 500VDC at 25°C			
	EMI Conduction & Radiation	Compliance to EN55015,FCC part 15			
	Harmonic Current	Compliance to EN61000-3-2 Class C(≥ 75% load),EN61000-3-3			
	EMS Immunity	Compliance to EN61000-4-2,3,4,5,6,8,11;EN61547,criteria B			
Others	MTBF	120K hours min. MIL-HDBK-217F(25°C)			
	Dimension(L x W x H)	300 x 98 x 38.5mm; 1308g/pcs			
Note	1. All specifications not specially mentioned are measured at 230VAC full load and 25°C ambient temperature. 2. Ripple & Noise are measured at 20MHz bandwidth by using a 12" twisted pair-wire terminated with 0.1uf & 47uf parallel capacitor. 3. Voltage Tolerance: includes line regulation, load regulation and set-up tolerance. 4. THD < 25% at 277VAC, full load.				

■ **Derating Curve**

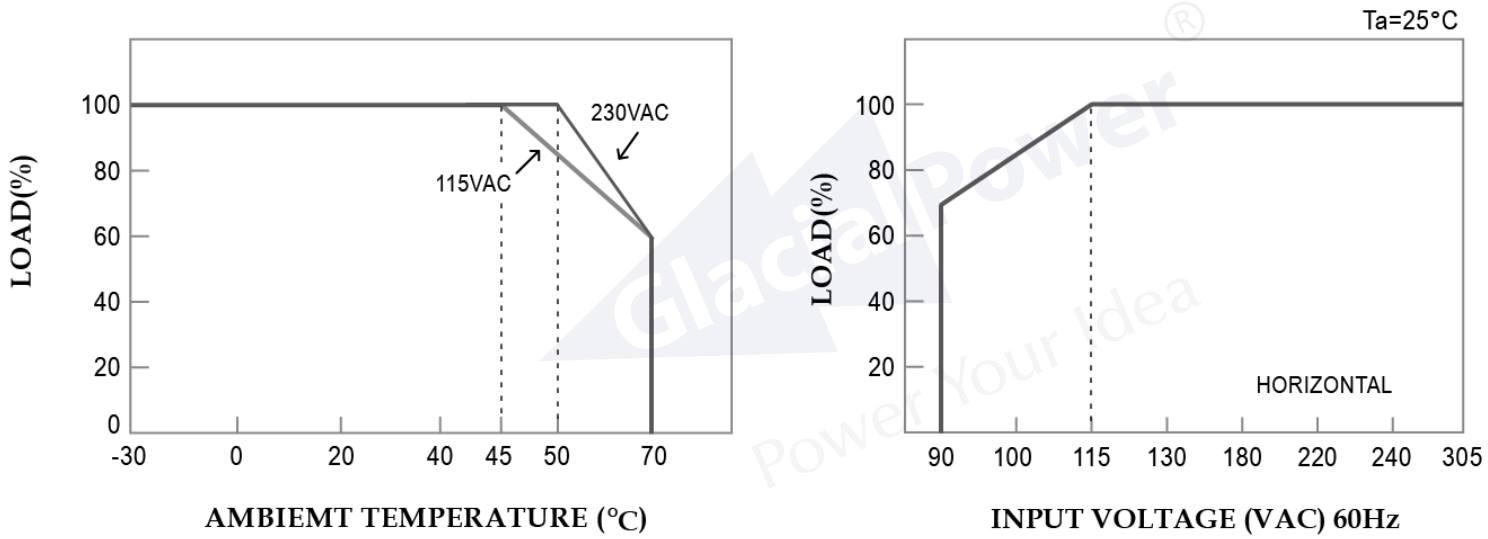

■ **Power Factor (PF) Characteristic (※Ta at 50°C)**

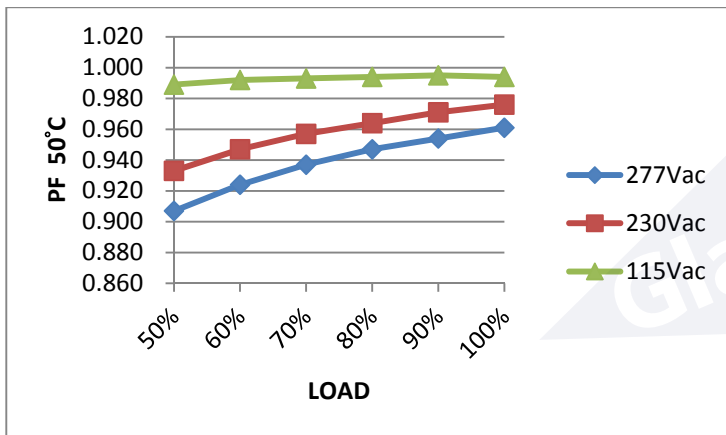

■ **Total Harmonic Distortion (THD) (※Ta at 50°C)**

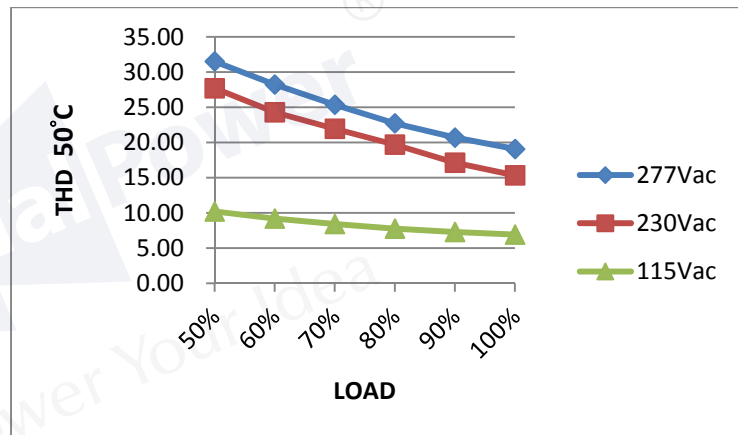

■ **Efficiency vs Load (※Ta at 50°C)**

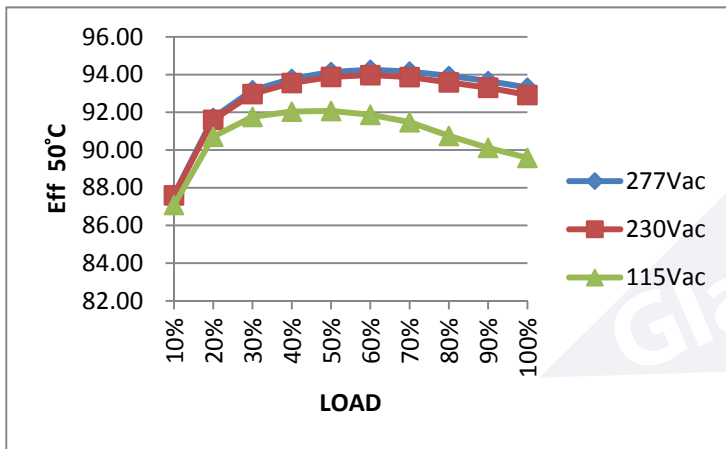

■ **3-in-1 Dimming Control (DC/ PWM/ Resistance)**

◆ **3-in-1 Dimmable Function Description**

(1) 0-100KΩ Resistance Dimmable (Typical):

Resistor	Single-driver	Short	9K	20K	30K	40K	50K	60K	70K	80K	95K	100K
	Multi-driver	Short/N	9K/N	20K/N	30K/N	40K/N	50K/N	60K/N	70K/N	80K/N	95K/N	100K/N
Vout Duty Cycle (%)		0%	2%	14.5%	25.9%	37.3%	48.7%	60.1%	71.5%	82.9%	100%	100%

※ The length of extended wire for DIM+/- shall not exceed 20 meters. (Wire ≤ 20m)

※ N=The number of dimmer drivers should not exceed 15. (N ≤ 15)

※ DIM+/- <7K or 7K/N Vout Duty cycle 0%

(2)DC: 0-10V Dimmable (Typical):

DIM(Voltage)	0V	0.9V	2V	3V	4V	5V	6V	7V	8V	9.5V	10V
Vout Duty Cycle (%)	0%	2%	14.5%	25.9%	37.3%	48.7%	60.1%	71.5%	82.9%	100%	100%

※ DIM+/- <0.7V Vout Duty Cycle 0%

(3)10V / PWM Dimmable (Typical):

DIM(10V/PWM Duty)	0%	9%	20%	30%	40%	50%	60%	70%	80%	95%	100%
Vout Duty Cycle (%)	0%	2%	14.5%	25.9%	37.3%	48.7%	60.1%	71.5%	82.9%	100%	100%

※ DIM+/- <7% Vout Duty Cycle 0%

◆ **Dimming Curve**

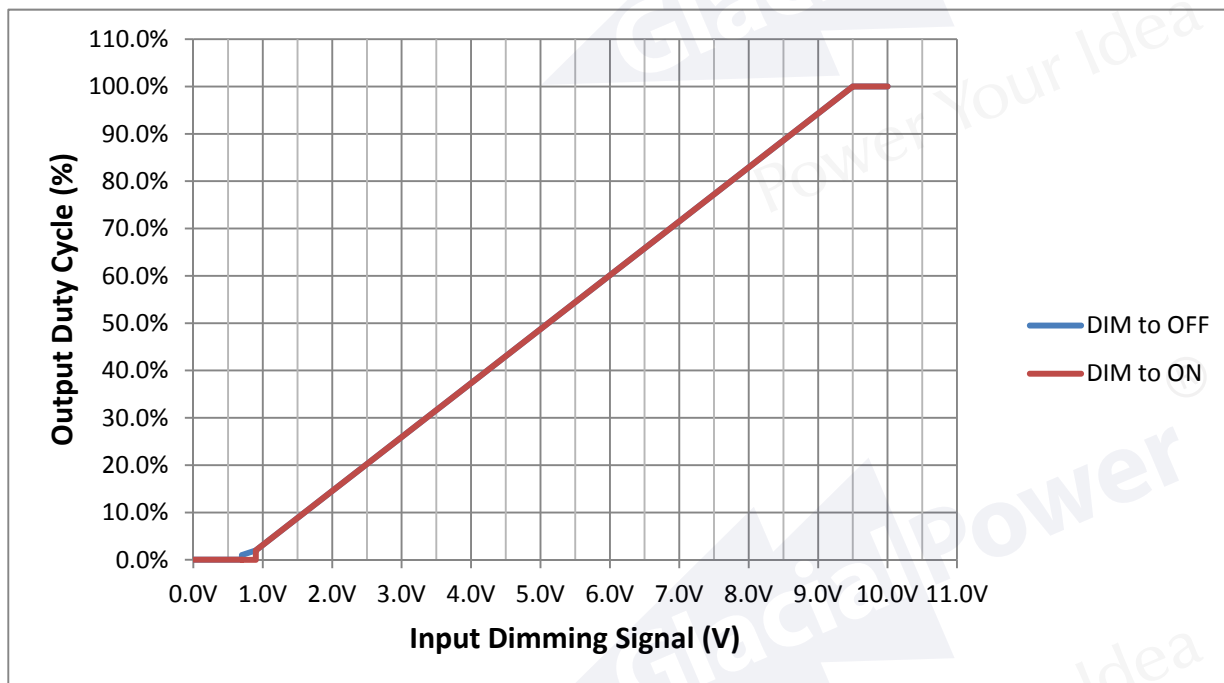

◆ **Dimming Curve**

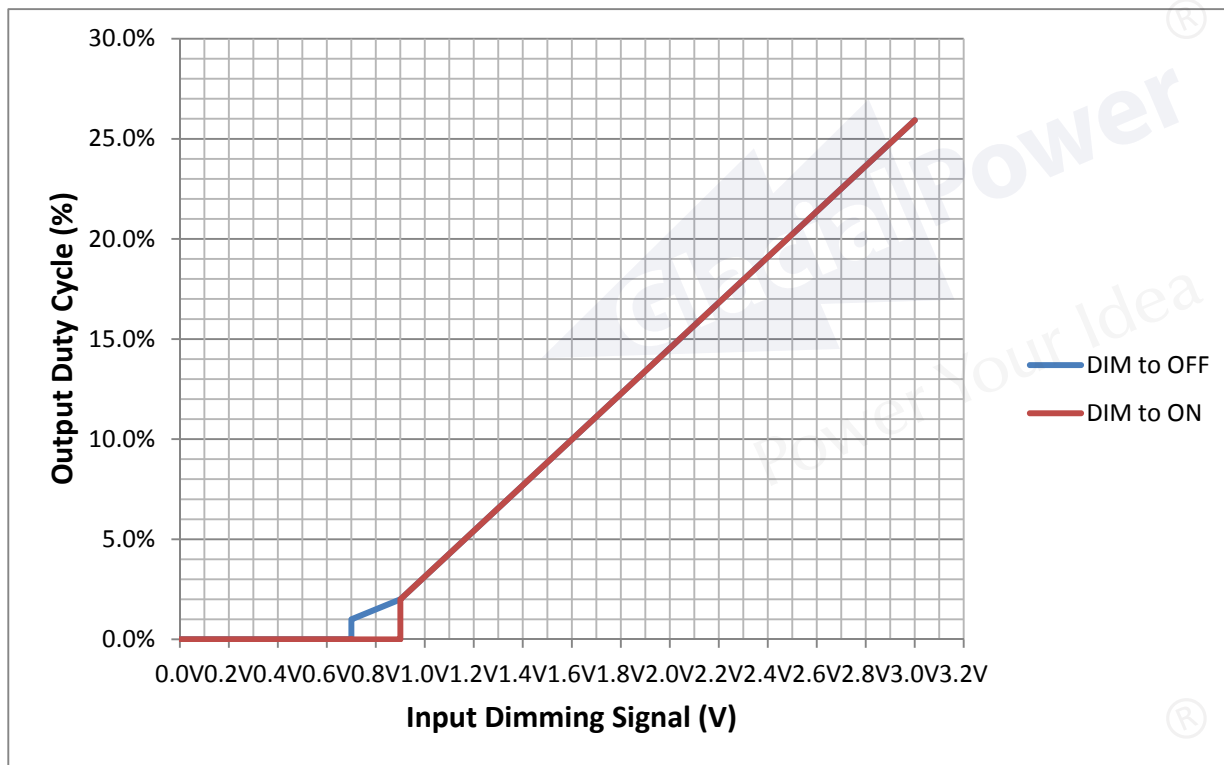

◆ **Wiring Diagram**

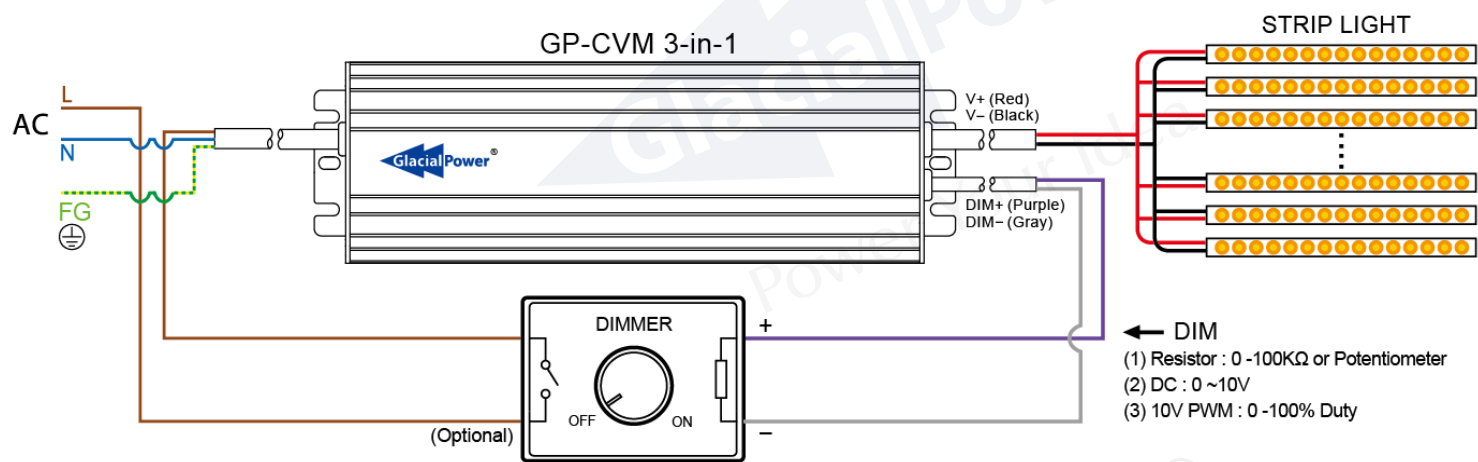

■ **DAI Interface**

◆ **DAI Function Description**

- (1) Apply DAI signal between DA wires
- (2) First step is fixed at 1% of output
- (3) Wiring diagram

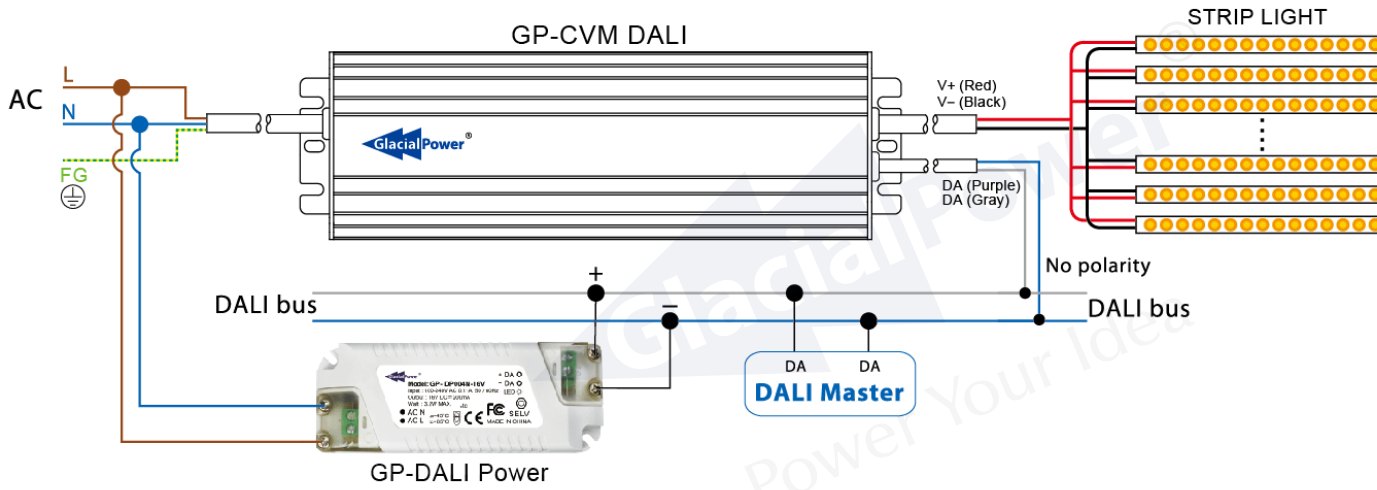

(4) Application diagram

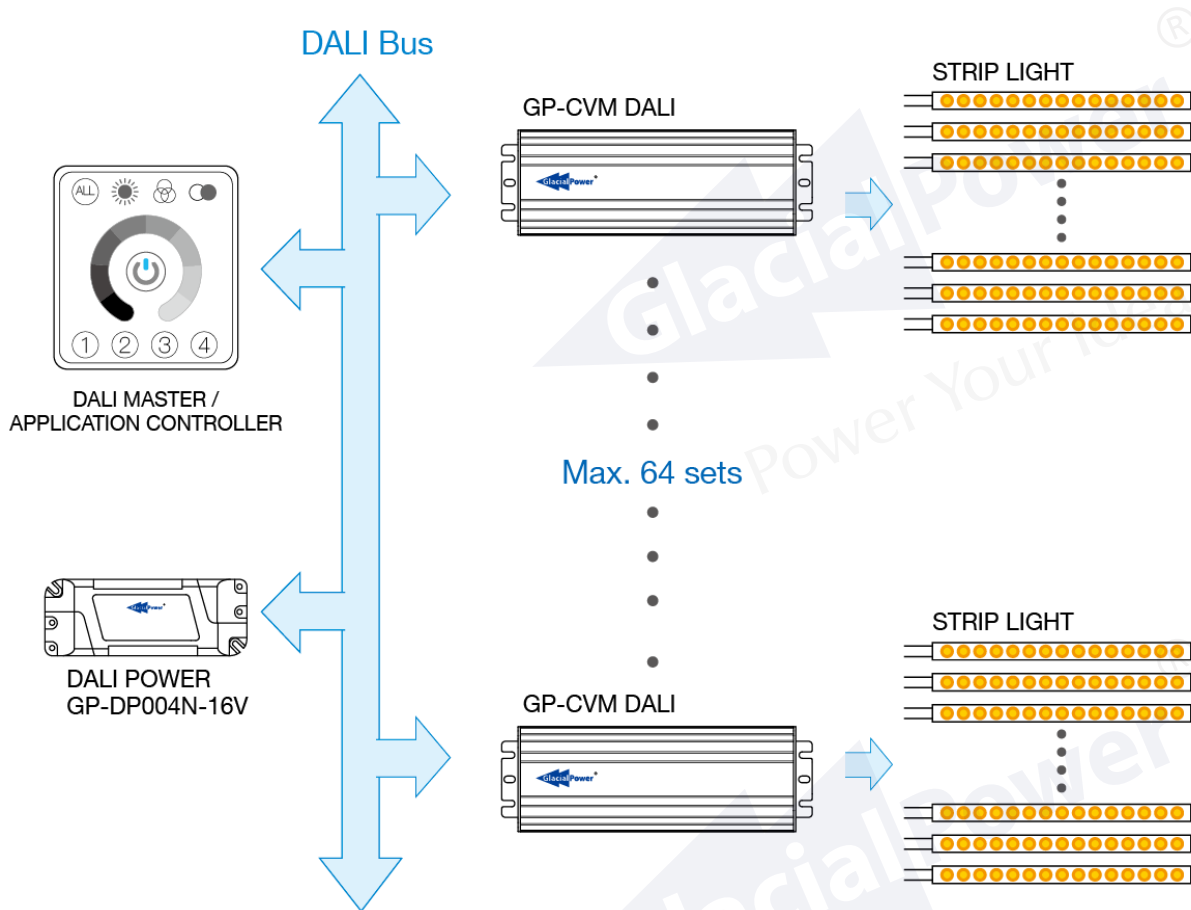

■ **Mechanical Specification**

GP-CVM400P-12Vx Series

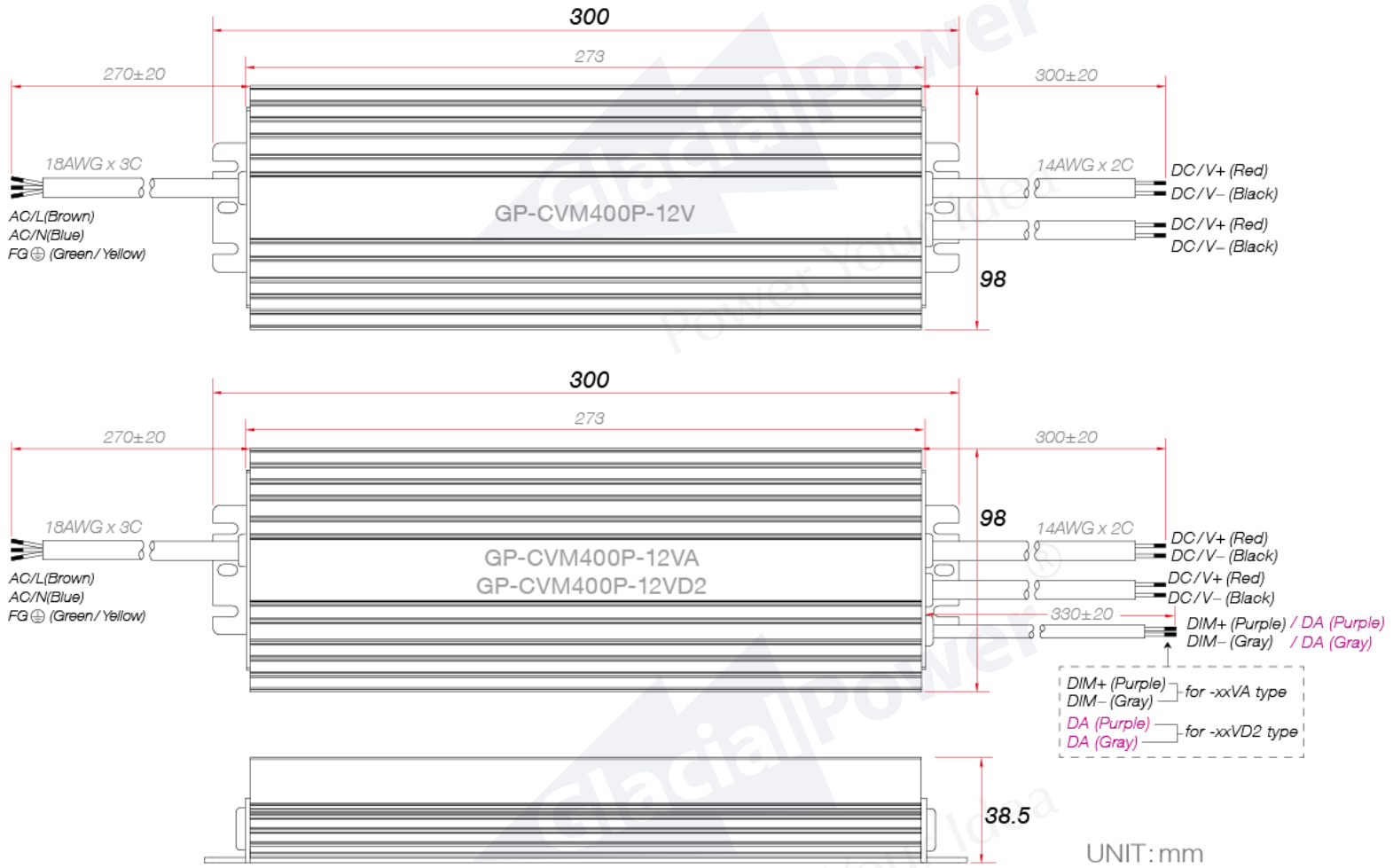

GP-CVM400P-12Vx Series



■ **Mechanical Specification**

GP-CVM400P-xxVx series

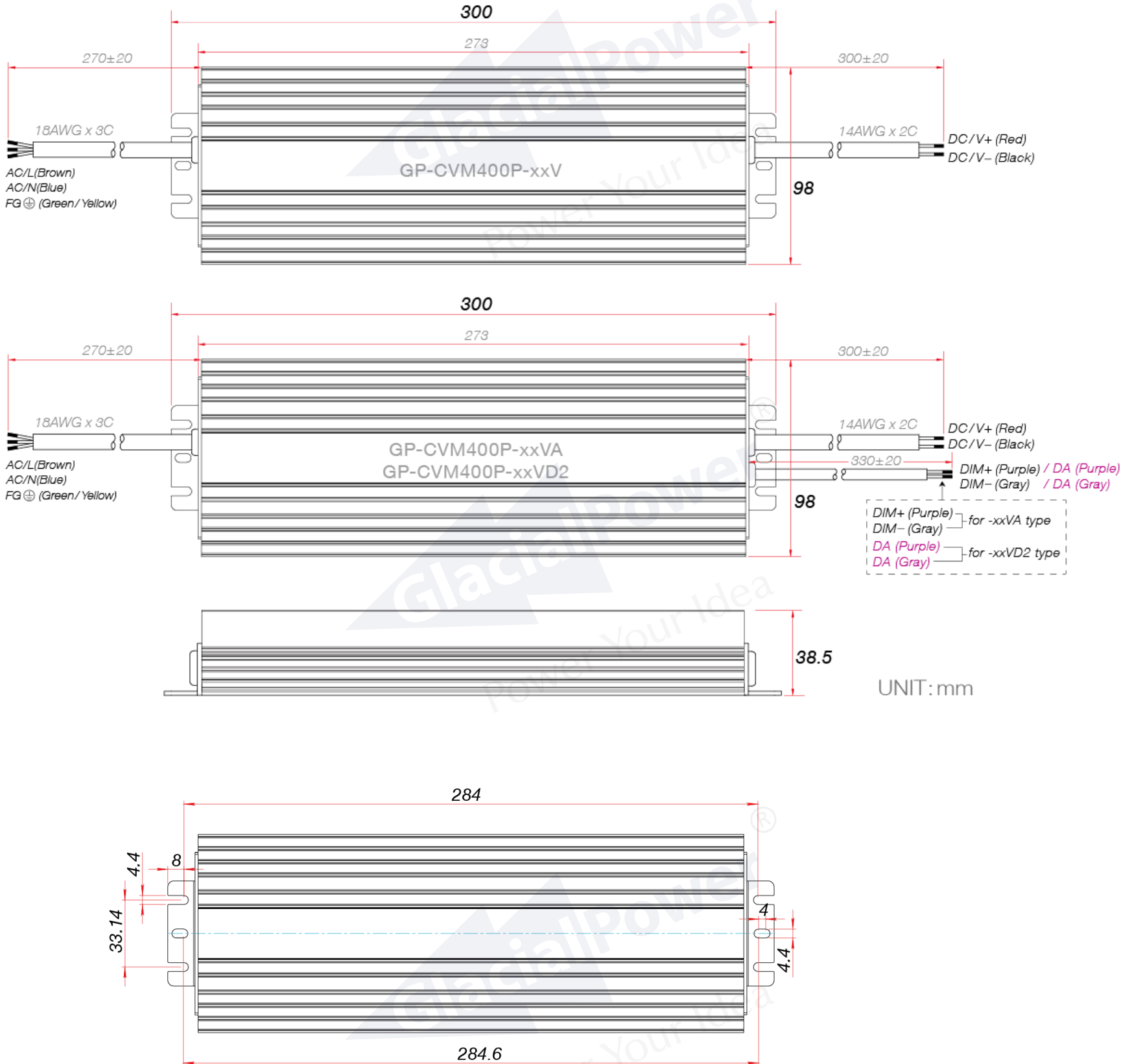

GP-CVM400P-xxVx series



GP-CVM400P-xxV



GP-CVM400P-xxVA



GP-CVM400P-xxVD2

The excellent heat dissipation design of GlacialPower GP-CVM LED driver to ensure high and stable reliability for long-term use.

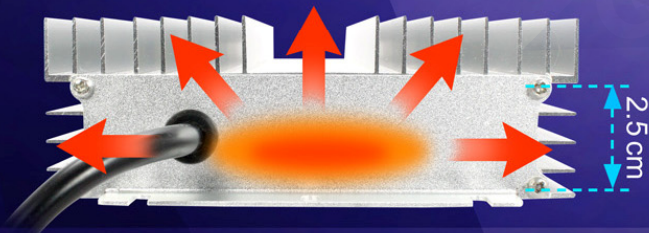

Very low profile design of aluminum housing –
Quickly transmit the heat from the inside components to the aluminum housing.



Large area of heat dissipation design –
Quickly dissipate the heat from aluminum fins into the surrounding air.

